

## User's Guide

### Valve Stem Position Transmitter

---

#### Introduction

In testing the dynamic operation of a controller, the Protuner is connected to measure both the *process variable signal (PV)* and the *controller output signal (PD)*. The typical loop analysis test procedure calls for the user to place the loop in manual and record a series of step changes in the controller output. The Protuner Loop Analysis procedure documents the loop *hysteresis* plus the *deadband*, *signal noise*, *process transfer function* and the recommended *loop tuning parameters*. The standard *Protuner* analysis assumes that the control valve position follows the output of the controller. That is, the controller output signal referred to as the *process demand signal (PD)* is the *implied valve position (IVP)*. In many cases, control problems are encountered because the valve I/P, positioner and actuator combination do not respond accurately to the output of the controller.

The *Protuner Valve Stem Position Transmitter* and *Pneumatic Transducer* assemblies are tools available to assist the user in trouble shooting and calibrating control valve operation. This manual will cover the basic connection and testing procedures for the *Stem Position Transmitter*.

---

#### Specifications

The *Stem Position Transmitter* is a cable-extension type linear position transmitter. When connected to the *Protuner 1600PC Interface*, the transmitter provides a voltage feedback signal proportional to the linear movement of the traveling stainless steel extension cable.

#### General

Range	0-127mm (0-5 inches)
Feedback	Signal 0 to 12 volts
Housing Material	Aluminum
Sensor	Conductive Plastic-Hybrid Potentiometer
Electrical Connection	3 Meter lead
Input Resistance	500 ohms
Power Rating (watts)	2.0 at 21° C
Operating Temperature	-6° C to 93° C

#### Wiring Information

Connector to Transmitter	MS3102E-14S-P6 Cannon
Connector to Protuner	9-Pin Sub D Male

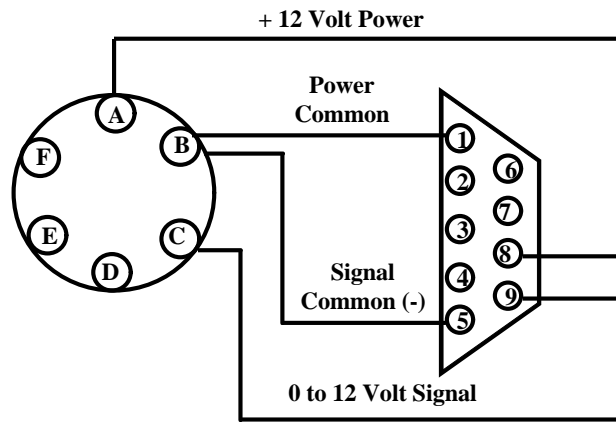

Wiring Diagram

### Connection

The *Stem Position Transmitter* can be connected to record the stem position movement from any linear or rotary valve. Since there is no standard actuator mounting, it may be necessary to make some minor field modifications to any particular actuator to connect the *Transmitter*.

#### General Connection to Sliding Stem Valves

- Place the *Transmitter* on the floor, piping or some other platform such that the extension wire is perpendicular to the stem of the valve and secure it.
- Connect a flexible extension cable [user supplied] to the *Transmitter* cable that is long enough to reach the valve stem connection point.
- Connect the extension wire, in excess of the current valve travel, to the valve stem. It may be necessary to connect the rigid stem position pointer to the stem connector to facilitate this connection.
- Stroke the valve. The total travel of the pre-extension, plus valve travel, cannot exceed 127 mm (5 inches).

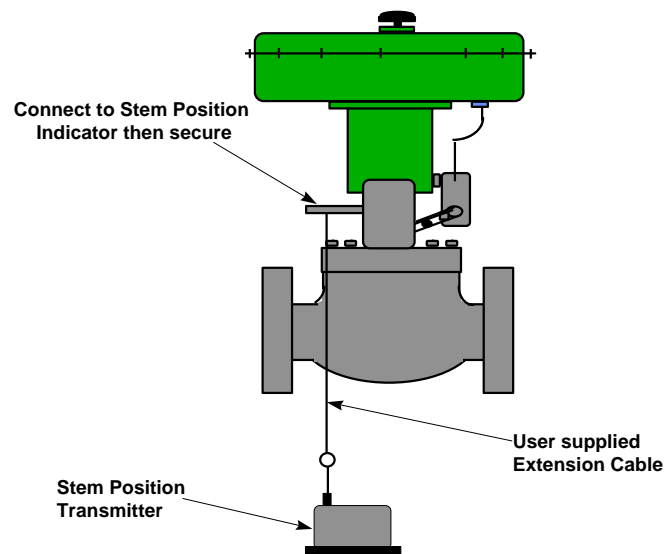

### General Connection to Rotary Valves

- Place the *Transmitter* on the floor, piping, or some other platform, such that the extension wire is perpendicular to the valve rotary stem position indicator.
- Connect a flexible extension cable [user supplied] to the transmitter cable. Be certain that it is long enough to reach the valve rotary indicator connection point. If the valve does not have a rotary shaft indicator, then mount a circular pulley to the shaft.
- Connect the extension wire, in excess of the current valve travel, to the valve shaft rotary position indicator.
- Stroke the valve. The total travel of the pre-extension, plus valve travel, cannot exceed 127 mm (5 inches) for the full 90-degree valve rotation.

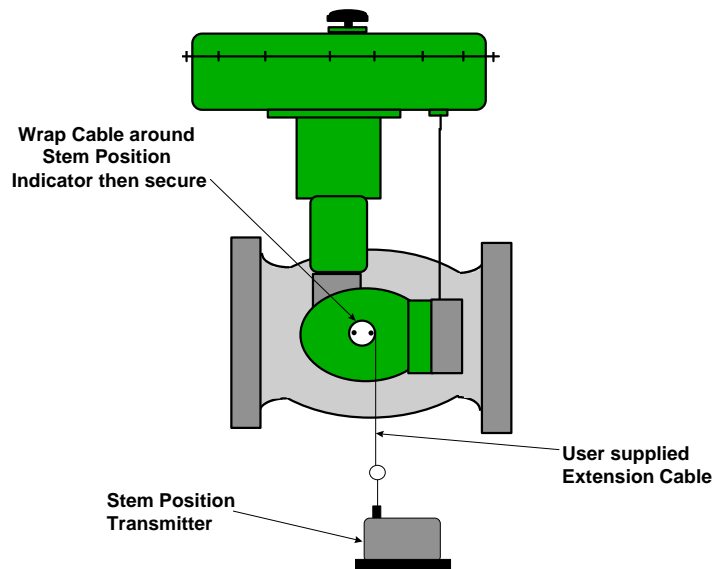

### Scaling the Protuner Software

Once connected to the valve, the *Transmitter* must be scaled at the *Protuner* to represent the 0% to 100% travel of the valve. With the *Transmitter* connected to the valve, enter the *Input Setup* for the *Protuner* and select the channel where the *Stem Position Transmitter* is located. Select the Scaling and Calculate Voltage option. Close the valve and enter 0 for the *Data 1* entry. Open the valve and enter 100% for the *Data 2* entry.