

Decoupling Interactive Multivariable Control Systems

As discussed in **Section 11**, if the relative gains are numerically close to each other, interaction fighting loops in a multivariable control system is likely to be a problem, particularly if the response times are comparable. In cases in which cross coupling is severe, the system can become unstable, and decoupling will be required. This section, will cover how to implement decoupling strategies in 2X2 and 3X3 interactive *multivariable* control systems.

Decoupling A 2x2 Interactive Control System

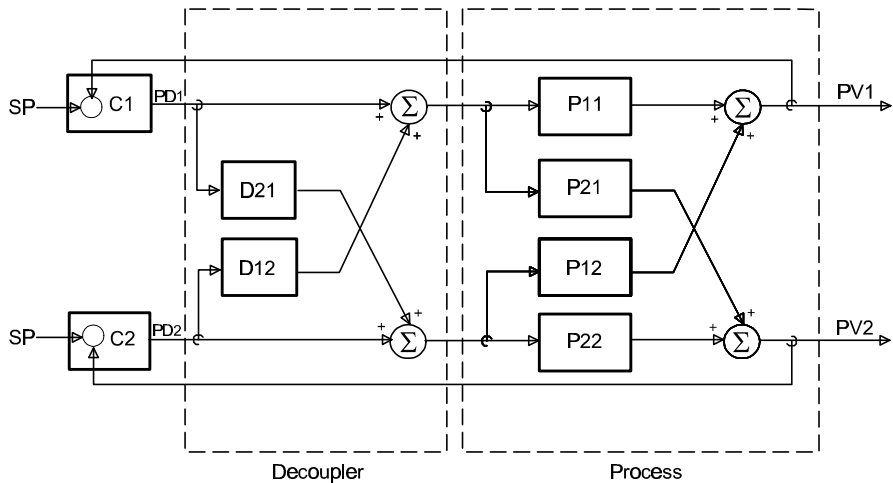

Figure 12.1 - Block Diagram of a 2X2 Interactive Control System with Feedforward Decouplers

A 2X2 interactive control system has two controllers, two final control elements, and variables to be controlled. Interaction is present because moving either valve causes both process variables to change.

The Protuner™ testing procedure is the same as described in **Section 11**. The calculation of the decouplers is the same as the calculation of the feedforward decouplers.

As illustrated, in the block diagram of the 2X2 interactive system, a change in the output of controller C_1 (PD_1) causes a change in both measured process variables PV_1 and PV_2 . Also, a change in the output (PD_2) of controller C_2 causes changes in both PV_1 and PV_2 . The Protuner™ test procedure is as follows:

1. Connect the Protuner™ to measure the input and output variables for both loops.
2. Scale and document the input channels.
3. Place both controllers in manual (open loop).
4. Step PD_1 in equal steps of approximately 3% to 5% up twice, down three times and back to its original position. After each step in PD_1 , wait for both PV_1 and PV_2 to stabilize at a new steady state.
5. Step PD_2 in equal steps of approximately 3% to 10% up twice, down three times and back to its original position. After each step in PD_1 , wait for both PV_1 and PV_2 to stabilize at a new steady state value.

Test Data Analysis

The test data gathered with the Protuner™ as outlined above, can now be analyzed to determine the four process transfer functions that describe the 2X2 interactive process. In general, the four process transfer functions are found by performing four separate Loop Analysis routines and saving the results as four separate Reports.

<i>Process (Tuning Record)</i>	<i>Relates Response of</i>	<i>To Changes In</i>
$P(s)_{11}$	PV_1	PD_1
$P(s)_{21}$	PV_2	PD_1
$P(s)_{22}$	PV_2	PD_2
$P(s)_{12}$	PV_1	PD_2

Table 12.1 - Variables for Loop Analysis Testing 2X2 Process

The Tuning Procedure to determine $P(s)_{11}$ and $P(s)_{22}$ determines the PID tuning parameters for controllers C_1 and C_2 .

The Loop Signature of the Loop Report screen also displays the process transfer function for each of the separate process response tests windowed. The process model in each process is in the terms of Process Gain (PG), Time Constant (TC) and Deadtime (DT). The process transfer function model constants found on each of the Loop Reports are as follows:

Process	Model Constants
P(s) ₁₁	PG ₁₁ , TC ₁₁ , DT ₁₁
P(s) ₂₁	PG ₂₁ , TC ₂₁ , DT ₂₁
P(s) ₂₂	PG ₂₂ , TC ₂₂ , DT ₂₂
P(s) ₁₂	PG ₁₂ , TC ₁₂ , DT ₁₂

Table 12.2 - Model Constants from Loop Analysis Test Reports

The dynamic decouplers for the control system are determined as follows:

Decoupler Tuning Constants

Decoupler	Transfer Function	Gain (Unitless)	Lead Seconds	Lag Seconds	Delay Seconds
D(s) ₁₂	P(s) ₁₂ /P(s) ₁₁	PG ₁₂ /PG ₁₁	TC ₁₁	TC ₁₂	(DT ₁₂ - DT ₁₁)
D(s) ₂₁	P(s) ₂₁ /P(s) ₂₂	PG ₂₁ /PG ₂₂	TC ₂₂	TC ₂₁	(DT ₂₁ - DT ₂₂)

Table 12.3 - Calculating Decoupler Tuning Parameters

NOTE

The sign for the individual process gains is not displayed on the Loop Analysis Reports. Therefore, to insure the correct sign for each process gain, look at the Plots of the test data. If the step change in the PD and the response of the PV are in the same direction, the process gain is positive. If the response of the PV is in the opposite direction of the PD step the process gain is negative.

Decoupling A 3x3 Interactive Control System

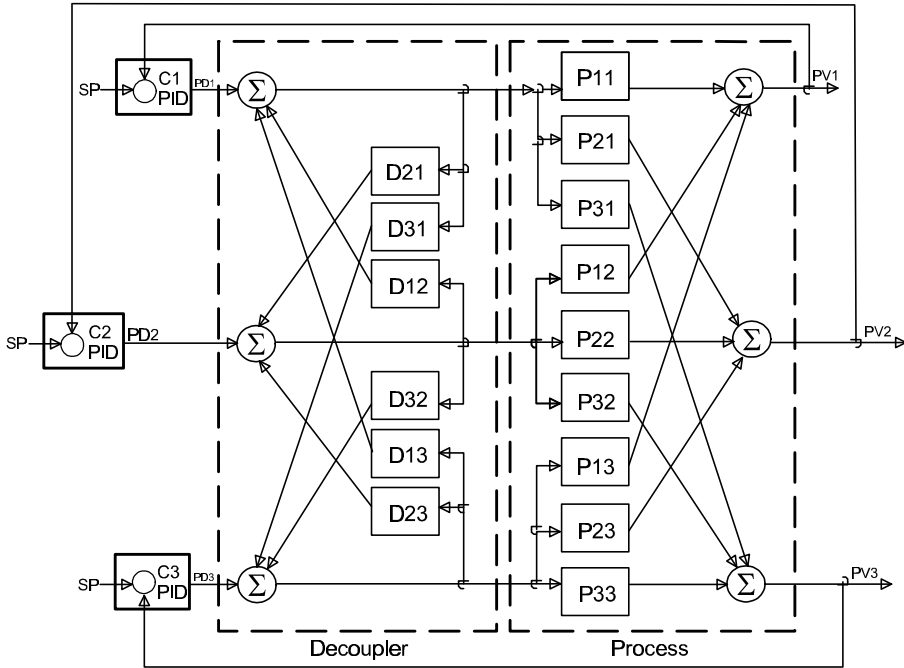

Figure 12.2 - Block Diagram of a 3X3 Interactive Control System with Decouplers

A 3X3 interactive control system has three controllers, three final control elements, and three variables to be controlled. Interaction is present because moving any of the three valves causes all three process variables to change. The Protuner™ testing procedure is the same as described in Decoupling a 2X2 Interactive Control System in this Chapter, except that control loop analysis testing of all three loops is required. As illustrated, in the block diagram of the 3X3 interactive system, a change in the output controllers C₁, C₂, and C₃ causes a change in all three measured process variables PV₁, PV₂, and PV₃.

The Protuner™ test procedure is as follows:

1. Connect the Protuner™ to measure the variables outlined above.
2. Scale and document the input channels.
3. Place all three controllers in manual (open loop).
4. Step PD₁ in equal steps of approximately 3% to 5% up twice, down three times and back to its original position. After each step in PD1 wait for PV₂ (Channel 2), PV₂ (Channel 4) and PV₃ (Channel 5) to stabilize at a new steady state.
5. Step PD₂ in equal steps of approximately 3% to 10% up twice, down three times and back to its original position. After each step in PD2, wait for PV₁ (Channel 2), PV₂ (Channel 4) and PV₃ (Channel 5) to stabilize at a new steady state.
6. Step PD₃ in equal steps of approximately 3% to 10% up twice, down three times and back to its original position. After each step in PD3, wait for PV₁ (Channel 2), PV₂ (Channel 4) and PV₃ (Channel 5) to stabilize at a new steady state.

Test Data Analysis

The test data, gathered with the Protuner™ as outlined above, can now be analyzed to determine the nine process transfer functions that describe the 3X3 interactive process. In general, the nine process transfer functions are found by performing three separate Loop Analysis routines and saving the results in nine separate Loop Analysis Records.

<i>Process</i>	<i>Relates Response of</i>	<i>To Changes In</i>
P(s) ₁₁	PV ₁	PD ₁
P(s) ₂₁	PV ₂	PD ₁
P(s) ₃₁	PV ₃	PD ₁
P(s) ₁₂	PV ₁	PD ₂
P(s) ₂₂	PV ₂	PD ₂
P(s) ₃₂	PV ₃	PD ₂
P(s) ₁₃	PV ₁	PD ₃
P(s) ₂₃	PV ₂	PD ₃
P(s) ₃₃	PV ₃	PD ₃

Table 12.4 - Variables for Loop Analysis Testing of 3X3 Process

The Tuning Procedures determine $P(s)_{11}$, $P(s)_{22}$, and $P(s)_{33}$, also the PID tuning parameters for controllers C_1 , C_2 , and C_3 . The Loop Analysis Report screen displays the process transfer function for each of the separate process response tests analyzed. The process model for each process is in the terms of Process Gain (PG), Time Constant (TC) and Deadtime (DT).

The process transfer function model constants found on each of the Loop Analysis Report screens are as follows:

Process	Model Constants
$P(s)_{11}$	$PG_{11}, TC_{11}, DT_{11}$
$P(s)_{21}$	$PG_{21}, TC_{21}, DT_{21}$
$P(s)_{31}$	$PG_{31}, TC_{31}, DT_{31}$
$P(s)_{12}$	$PG_{12}, TC_{12}, DT_{12}$
$P(s)_{22}$	$PG_{22}, TC_{22}, DT_{22}$
$P(s)_{32}$	$PG_{32}, TC_{32}, DT_{32}$
$P(s)_{13}$	$PG_{13}, TC_{13}, DT_{13}$
$P(s)_{23}$	$PG_{23}, TC_{23}, DT_{23}$
$P(s)_{33}$	$PG_{33}, TC_{33}, DT_{33}$

Table 12.5 - Model Constants from Loop Analysis Test Reports

The dynamic decouplers for the control system are determined as follows:

Decoupler Tuning Constants

Feedforward Decoupler	Transfer Function	Gain (Unitless)	Lead Seconds	Lag Seconds	Delay Seconds
$D(s)_{12}$	$P(s)_{12}/P(s)_{11}$	PG_{12}/PG_{11}	TC_{11}	TC_{12}	$(DT_{12} - DT_{11})$
$D(s)_{13}$	$P(s)_{13}/P(s)_{33}$	PG_{13}/PG_{33}	TC_{33}	TC_{13}	$(DT_{13} - DT_{33})$
$D(s)_{14}$	$P(s)_{14}/P(s)_{44}$	PG_{14}/PG_{44}	TC_{44}	TC_{14}	$(DT_{14} - DT_{44})$
$D(s)_{21}$	$P(s)_{21}/P(s)_{22}$	PG_{21}/PG_{22}	TC_{22}	TC_{21}	$(DT_{21} - DT_{22})$
$D(s)_{23}$	$P(s)_{23}/P(s)_{33}$	PG_{23}/PG_{33}	TC_{33}	TC_{23}	$(DT_{23} - DT_{33})$
$D(s)_{24}$	$P(s)_{24}/P(s)_{44}$	PG_{24}/PG_{44}	TC_{44}	TC_{24}	$(DT_{24} - DT_{44})$
$D(s)_{31}$	$P(s)_{31}/P(s)_{11}$	PG_{31}/PG_{11}	TC_{11}	TC_{12}	$(DT_{12} - DT_{11})$
$D(s)_{32}$	$P(s)_{32}/P(s)_{22}$	PG_{32}/PG_{22}	TC_{22}	TC_{32}	$(DT_{32} - DT_{22})$
$D(s)_{34}$	$P(s)_{34}/P(s)_{44}$	PG_{34}/PG_{44}	TC_{44}	TC_{34}	$(DT_{34} - DT_{44})$

Table 12.6 - Calculating Decoupler Tuning Parameters for 3X3 Process

NOTE

Again, the sign for the individual process gains is not displayed on the Loop Analysis Reports. Therefore, to insure the correct sign for each process gain, look at the plots test data to determine the correct sign for each process gain in the table.

